

CARTEN

FLOW SOLUTIONS - **WE GO BEYOND**

INTRODUCING CARTEN'S OMNIA MANUAL PINCH VALVE SERIES



Omnia Manual Pinch Valve Series

Manual Pinch Valves for Single-Use Applications

The patented BPV series can be used on any tubing or flow kit, including reinforced tubing, and allows the customer to change tubing line size on site through the changeout of an insert kit.

Key Features

For use with all Tubing Brands/Compounds

Available in line sizes from 1/16" ID to 1" ID

Retrofitted on site allowing numerous tubing line sizes – Insert Kit

Two footprints available – Small BP25 and Large BP50

Typical Applications

All upstream, downstream, fill-finish applications in single-use, applications requiring multiple line size interchangeability, high pressure pump shut-off, PUPSIT, sampling, fluid transfer applications.

Key Specifications

Materials of Construction	Cleanliness	Specifications	Options
304/316 stainless	Manufactured in a White Room	100% Leak tested as per ASME BPE / ANSI FCI 70/2 Class VI	Multiple brands, compounds, and tubing line sizes
PTFE-coated bonnet	One piece valve assembly - lockout screw design	Tubing: 300 without failure using flowing water at max pressure of tubing	Custom insert kits (holder and compressor)
Body, Compressor: ASTM A479 316L (S31603)	Rapid change-out of tubing line sizes – Suitable for continuous manufacturing	Electropolished as per ASME BPE, ASTM A967	Multiple tube holders allowing tubing line size changeout
Light weight PPS handwheel (40% G.F)	No lubricant or grease at tubing insert area	Passivated as per ASME BPE, ASTM B912	Custom stainless steel mounting options available on request

Omnia Series Pinch Valves

Multi-Use Pinch Valves for SU
(Single-Use) Bioprocessing Applications

Carten's PBV Series sanitary manual pinch valve offers unique advantages over traditional "throw away" polymer components for shut-off single use applications. The valve structure is manufactured utilizing polished stainless steel, allowing all tubing brands and compounds to be operated uniformly from batch-to-batch, with no physical breaks in the process tubing preventing any possibility of contamination.

Single use tubing sizes from 1/16" to 1" ID (Internal Diameter) can be utilized with these valves. The tubing inserts can be changed out if different size tubes are utilized within the range of the valve.

Carten's pinch valve for single use applications provides the most efficient and best-in-class for optimum flow control, adaptability, minimal footprint, cost effective, maintenance friendly design for critical sterile processes.

Advantages of Carten's Omnia Valve:

- Patented design
- Minimum valve sizes - Interchangeable tubing insert kit
- Reusable valve assembly
- Fine control
- Suitable for 1/16" – 1" (ID) tubing
- Suitable for all tubing brands / compounds
- Quick changeout of single use tubing sets
- No lubricants used
- Rapid change-out of tubing
- Ease of maintenance
- Dome design for high batch cycles
- Suitable for continuous manufacturing

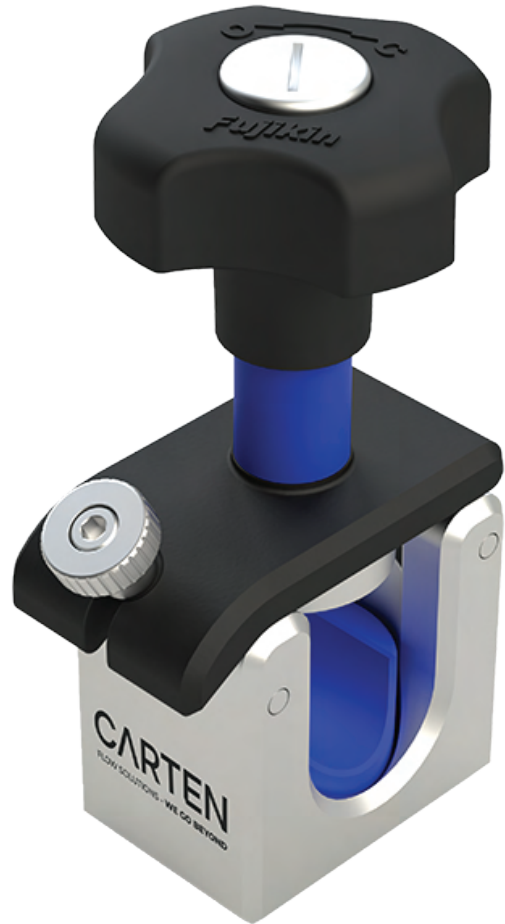

SPECIFICATIONS - BPV SERIES MANUAL PINCH VALVES

Control Type	Manual
Line Pressure Rating	Max 5Bar (72.5psi) (dependent on braided tubing used, per line size)
Operating Temperature	Tubing Dependent
Materials of Construction	Body, Compressor: ASTM A479 316L (S31603) Handwheel: PPS (40% G.F.)

PERFORMANCE

Leak Rate	0cc/min (ANSI FCI70/2 Class IV) Dynamic (Flowing) Water 0cc/min (ANSI FCI70 /1 Class VI) Static (Compressed) Air
Life Cycle	Tubing: 300 without failure using flowing water at max pressure of tubing
Particulates	As per USP 788, real-time analysis
Hold Test	TPE, PCS, and traded tubing held closed at atmosphere, 48 hrs, tubing re-opens automatically

SELECTOR

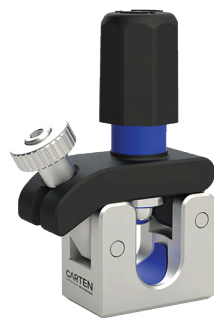

Small (BP25)

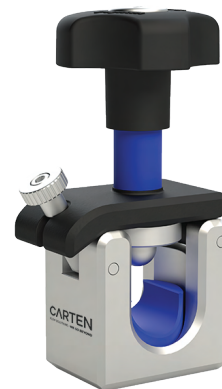

Large (BP50)

Tubing Size	1/16" - 1/2" ID	3/8" - 1" ID
PCS (Peristaltic Pump Tubing)	Y	Y
TPE (Thermoplastic Elastomer Tubing)	Y	Y
Braided Tubing 2 BAR (29 PSI) Max	Y	Y
Braided Tubing 5 BAR (72.4 PSI) Max	Y	Y

KEY FEATURES - OMNIA SERIES PINCH VALVES

- **High-pressure capability:** From unique holder compression design – braided tubing and hardened silicon can be controlled and sealed with ease.
- **Holder tubing flexibility (same holder for tubing):** Holder geometry and additional force generation allows flexibility to use the same interchangeable parts across different line sizes – for example, 1" ID can be combined with all tubing from 1.34" – 1.44" OD using the same valve parts.
- **Rapid batch change-out (full face of valve exposed):** Full access to holder when rotated to allow rapid change-out of tubing with no restriction from holder design.
- **Process of Record:** Valves installed with biologic manufacturers, CDMO's, and OEM'S in all global regions, multiple applications, and for many years, Performance is proven in the field.
- **All standard tubing is covered in two sizes:** All standard applications utilising silicon or TPE tubing up to 1.5 BAR is covered using just the BP25/ BP50 valve sizes.
- **2-piece change-out for new line size:** Line size of tubing can be changed through the simple swap out of just two components – the unique patented valve parts - the compressor and holder.
- **Lockout Option for Stem:** Lockout tagout device can be added simply to valve design to prevent operator pinch point in the event of critical instrument air failure.



DIMENSIONS - BP50 SERIES PINCH VALVES

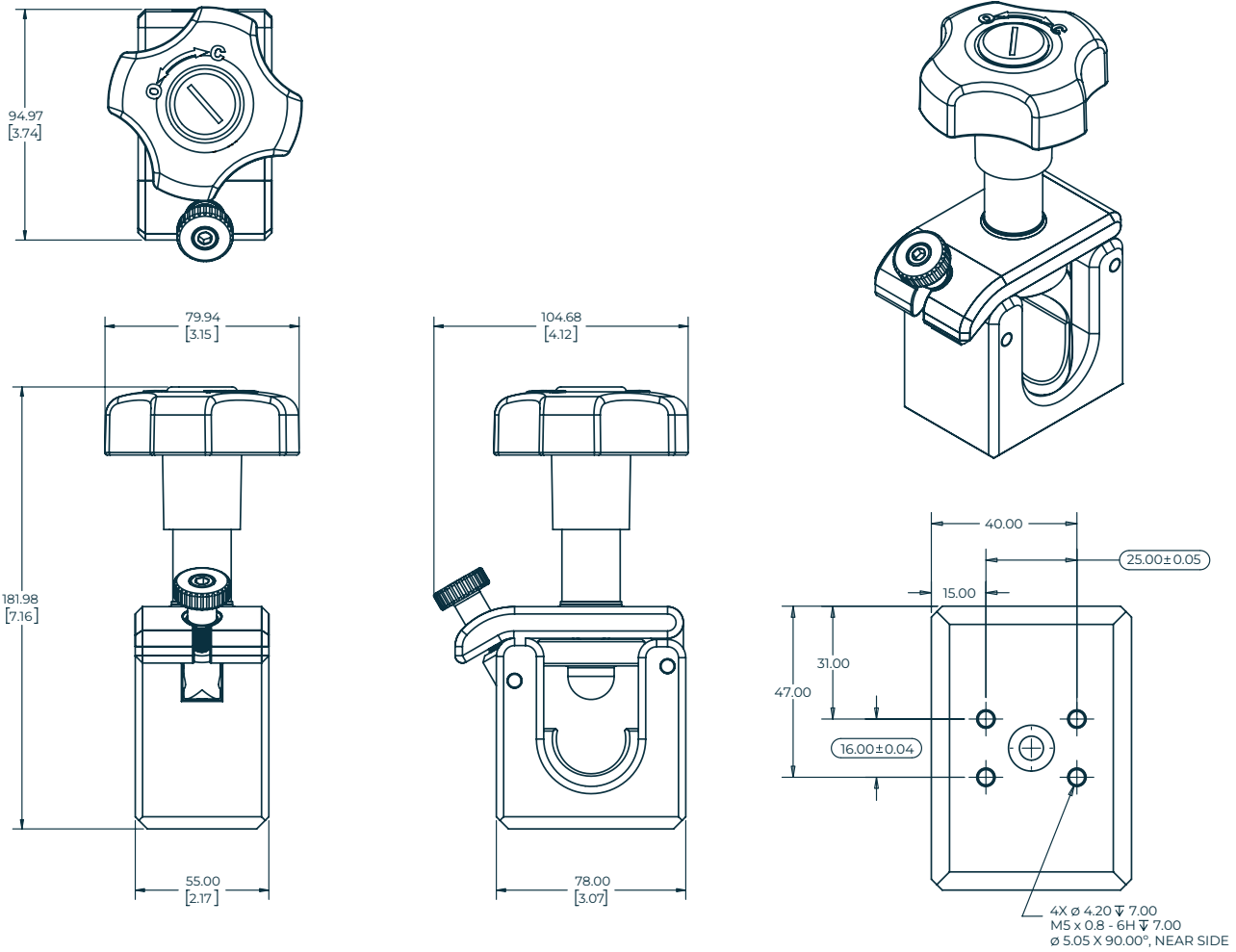

DIMENSIONS - BP25 SERIES PINCH VALVES

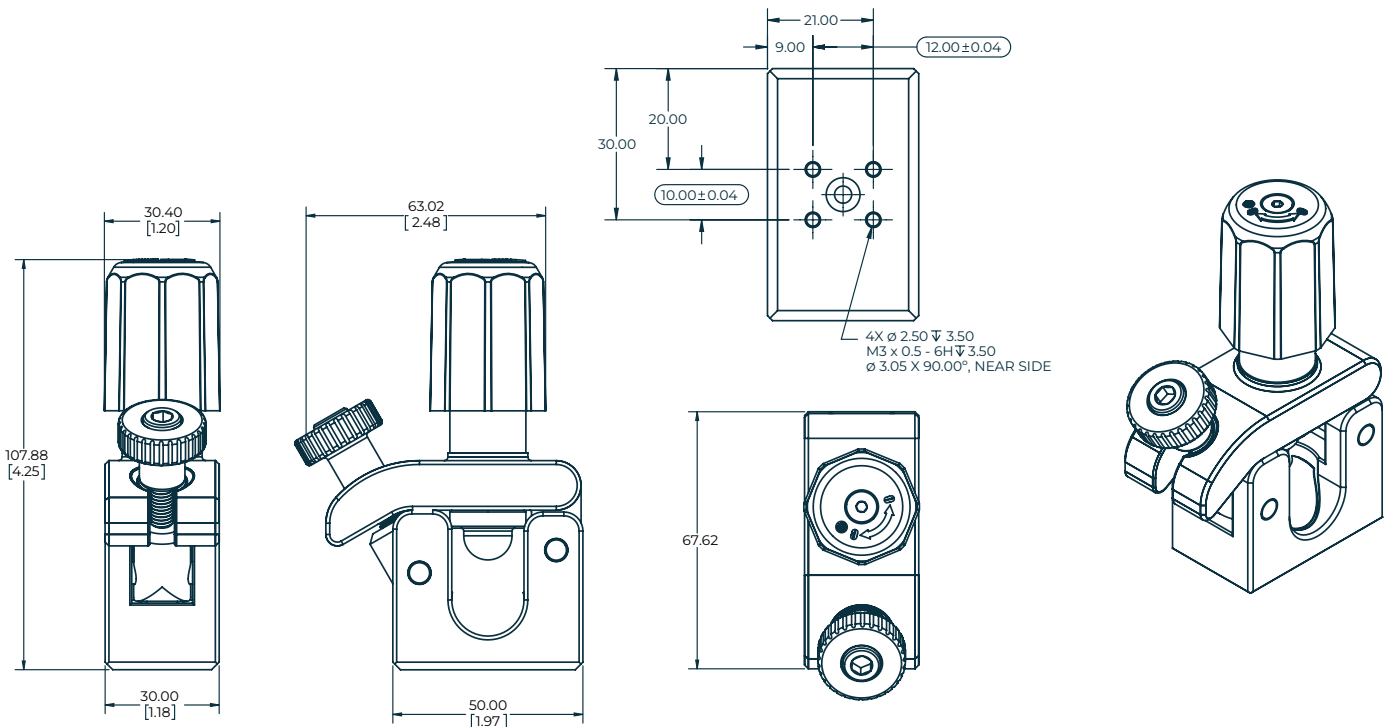

ORDERING INFORMATION - BPV SERIES PINCH VALVES

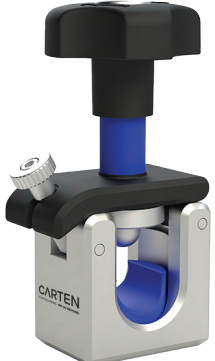
				
			Small (BP25)	Large (BP50)
Tubing Size				
Code	ID	OD		
B6	1/8"	1/4"	BP25-VL-500-B6	
C8	3/16"	3/8"	BP25-VL-500-C8	
C9	1/4"	7/16"	BP25-VL-500-C9	
D9	1/4"	1/2"	BP25-VL-500-D9	
D11	3/8"	5/8"	BP25-VL-500-D11	BP50-VL-500-D11
D14	1/2"	3/4"	BP25-VL-500-D14	BP50-VL-500-D14
F14	1/2"	7/8"		BP50-VL-500-F14
D17	3/4"	1"		BP50-VL-500-D17
F17	3/4"	1 1/8"		BP50-VL-500-F17
F19	1"	1 3/8"		BP50-VL-500-F19

Other sizes available upon request.

ID = INSIDE DIAMETER OF TUBING
OD = OUTSIDE DIAMETER OF TUBING

TUBING INSERT KIT ORDERING INFORMATION

			Small (BP25)	Large (BP50)
Tubing Size				
Code	ID	OD		
B6	1/8"	1/4"	BP25-DP-114	
C8	3/16"	3/8"	BP25-DP-208	
C9	1/4"	7/16"	BP25-DP-209	
D9	1/4"	1/2"	BP25-DP-309	
D11	3/8"	5/8"	BP25-DP-311	BP50-DP-311
D14	1/2"	3/4"	BP25-DP-314	BP50-DP-314
F14	1/2"	7/8"		BP50-DP-514
D17	3/4"	1"		BP50-DP-317
F17	3/4"	1 1/8"		BP50-DP-517
F19	1"	1 3/8"		BP50-DP-519

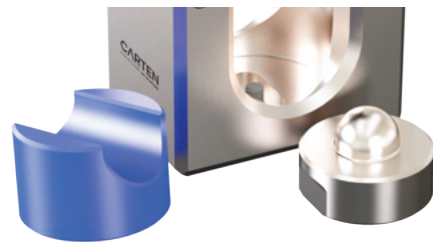

Tubing Insert Kit

OTHER SIZES AVAILABLE UPON REQUEST

Note: Tubing insert kits are to be utilised if the tubing line size change within the valve operating tube size limits.

Contact us to review specific additional valve options.

INTERATED SINGLE - USE SOLUTIONS - FLUID TRANSFER MODULES

CARTEN

FLOW SOLUTIONS - **WE GO BEYOND**

Carten Controls Ltd,
Unit 613, Northern Extension Waterford
Industrial Estate,
Cleaboy Road,
Waterford Ireland
X91 F2DE

Tel: +353 (0)51 355436
Email: sales@cartencontrols.com
Website: <http://www.cartencontrols.com>

Fujikin (Deutschland) GmbH
Immermannstraße 33 -
D-40210 Düsseldorf, Germany.

Tel: +49 (0) 211-350458
Email: info@fujikin.de
Website: <http://www.fujikin.de>

Carten Controls and Fujikin Deutschland are members of the Fujikin Carp Group (FCG) with Headquarters in Osaka Japan.