

# CARTEN

FLOW SOLUTIONS - **WE GO BEYOND**

## INTRODUCING CARTEN'S SPDS SERIES

ULTRA-HIGH PURITY  
DIAPHRAGM VALVES

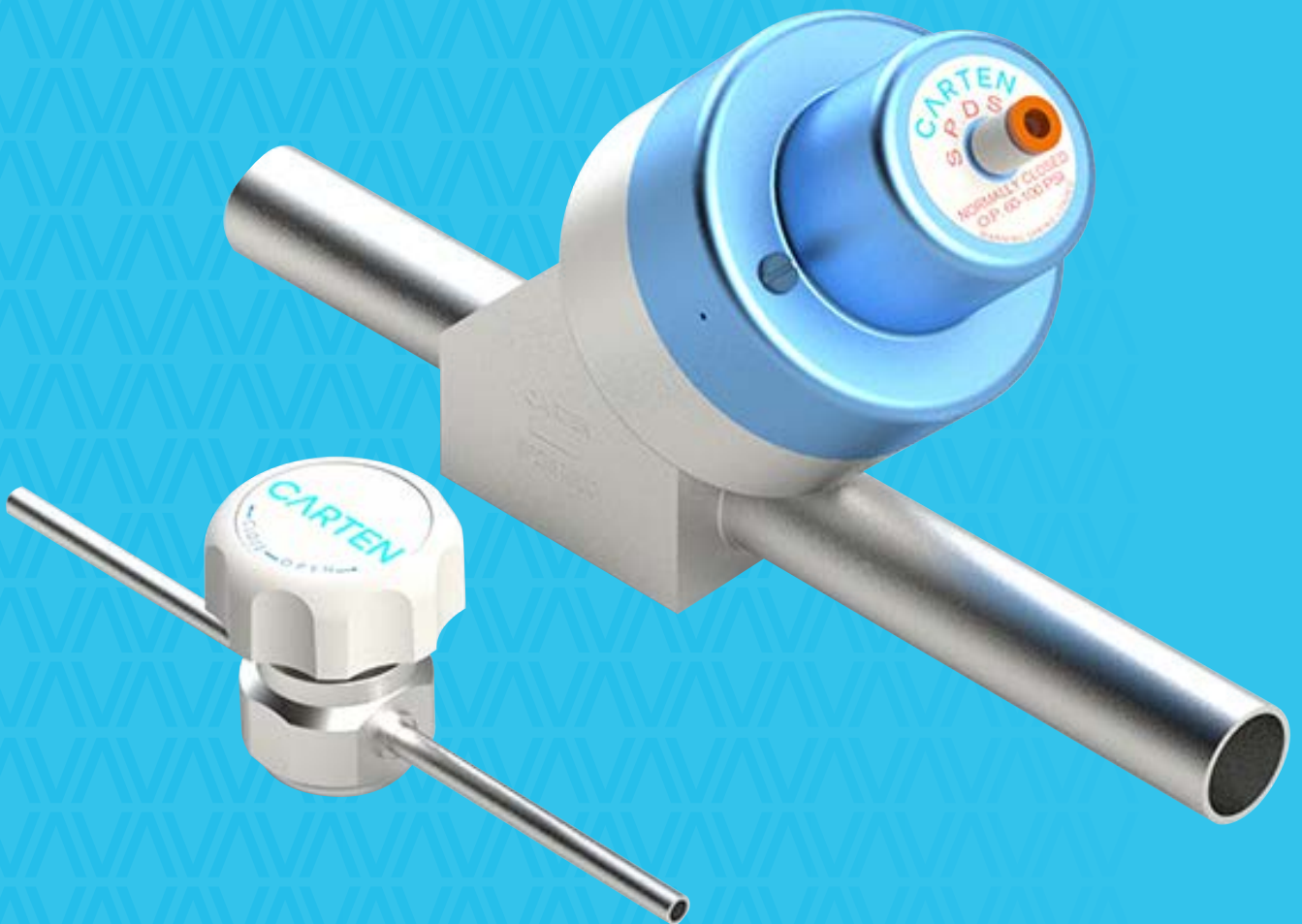

## SPDS Series

### Ultra-High Purity Diaphragm Valves

The No.1 UHP diaphragm valve-of-choice for semiconductor applications allows the highest flow rates (Cv) in the industry.

#### Key Features

Available in line sizes up to 1"

Metal-to-metal external seals

Pneumatic or manual interchangeability

Standard & bespoke multiport / block options

#### Typical Applications

Lateral points-of-connection (POC), tool hook-up shut-off, ultra-high-purity gas control for point-of-use service, valve manifold boxes (VMB), gas distribution panels, gas sticks, and critical application containment functionality.

#### Key Specifications

Materials of Construction	Cleanliness	Specifications	Options
316L stainless body	Manufactured in Class 10 Cleanroom	Leak tested using Mass spectrometer $<1 \times 10^{-9}$ mbar.l/s	Manual or pneumatic, LOTO failsafe configurations
Elgiloy Diaphragm	Zero particles @0.1 $\mu$ m	$<10$ Ra micro-inch surface roughness	PFA / PI seat high temperature (up to 150C)
Barstock-only source	$<10$ ppb O <sub>2</sub> /H <sub>2</sub> O outgassing	Vacuum and pressure tested 100% production control	4/20mA switching / signalling automation (pneumatic only)
PCTFE standard seat (minimal volume)	Cleaned using 18.2M $\Omega$ .cm DI water	Manual 375 p.s.i. Pneumatic 250 p.s.i.	0.41 - 9.0 Cv (flow coefficient)



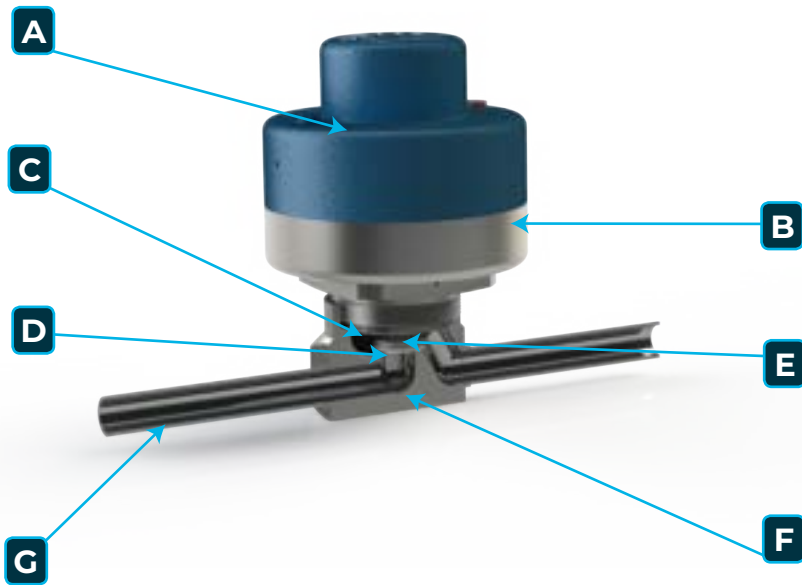

## Material of Construction

Item	Part
A	Aluminium, SS 303/304, Viton®
B	Bonnet Stainless Steel
C	Elgiloy Diaphragms (Tied-Diaphragms)
D	Seat PCTFE
E	Seat Holder 316L St. St.
F	Body Barstock 316L St. St.
G	Tube Ends 316L St. St.

® Viton is a registered trademark of DuPont

## SPDSA Series Technical Specifications

Maximum Operating Pressure		SPDSA Series		Vacuum to 250 psi. (17.23 BAR) See below for pneumatic actuation pressures	
Maximum Operating Temperature		PCTFE Seat*		-30°C (-22°F) to 82°C (180°F) 302°F (150°C)	
Inch Model		Control Function	Cv	Cycle Life**	Actuation Pressure
Description	Line Size (Body) Size				
SPDSA 500	.500 (.500)	NO, NC	2.50	100,000	60-100PSIG (4.14-6.9BAR)
SPDSA 755	.750 (.500)	NO, NC	2.60	100,000	60-100PSIG (4.14-6.9BAR)
SPDSA 750	.750 (.750)	NO, NC	3.10	100,000	60-100PSIG (4.14-6.9BAR)
SPDSA 1075	1.000 (.750)	NO, NC	3.10	100,000	60-100PSIG (4.14-6.9BAR)
SPDSA 751***	.750 (1.000)	NO NC	5.50	50,000	80-100PSIG (5.51-6.9BAR) 90-100PSIG (6.20-6.9BAR)
SPDSA 1000***	1.000 (1.000)	NO NC	6.50	50,000	80-100PSIG (5.51-6.9BAR) 90-100PSIG (6.20-6.9BAR)
<b>Helium Leak Test</b>		<b>Inboard Across the Seat Outboard Pressure Test</b>		<1 x 10 <sup>-9</sup> scc/s He (1 x 10 <sup>-10</sup> Pa-M <sup>3</sup> /s) <1 x 10 <sup>-9</sup> scc/s He (1 x 10 <sup>-10</sup> Pa-M <sup>3</sup> /s) <1 x 10 <sup>-6</sup> scc/s He (1 x 10 <sup>-7</sup> Pa-M <sup>3</sup> /s)	
<b>Cleanliness and Packaging</b>		Assembled and tested in Class 10 Cleanroom. Purged and Final Packaged in Class 10 Cleanroom. Double-bag packaging with Ultra-High Purity N <sup>2</sup> gas environment.			
<b>Standard Finish</b>		Electropolished to 10 Ra µin Max (0.25 µm) on all wetted surfaces			
<b>Options</b>		450psi pressure rated model available for NC versions of SPDSA 500/755/750/1075 Optional surface finishes available. Testing: particle, moisture, O <sup>2</sup> , SEM, ESCA and AES on request. Purge connections and Purge valves are available as requested. Face seal, twin ferrule compression fittings available up to 1" lines			

\* For more options contact sales

\*\*Cycle life based on minimum pressure rating, through a standardised testing of sample set under laboratory conditions

\*\*\*SPDSA751 & SPDSA1000 Normally Open Pressure Rating is 150psig

## Material of Construction

Item	Part
A	ABS
B	Bonnet Stainless Steel
C	Elgiloy Diaphragms (Tied-Diaphragms)
D	Seat PCTFE
E	Seat Holder 316L St. St.
F	Body Barstock 316L St. St.
G	Tube Ends 316L St. St.

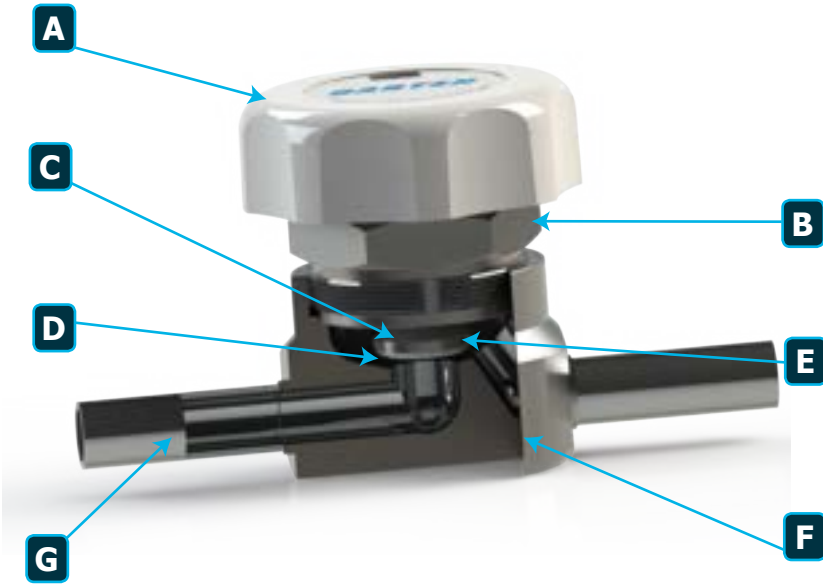

## SPDS Series Technical Specifications

Maximum Operating Pressure	SPDS Series	Vacuum to 375 psi. (25.85 BAR)																													
Maximum Operating Temperature	PCTFE Seat Vespel® Seat	-30°C (-22°F) to 82°C (180°F) 302°F (150°C)																													
Helium Leak Test	Inboard	<table border="1"> <thead> <tr> <th colspan="2">Inch Model</th> <th rowspan="2">Cv</th> </tr> <tr> <th>Description</th> <th>Line Size (Body) Size</th> </tr> </thead> <tbody> <tr> <td>SPDS 250</td> <td>.250 (.250)</td> <td>0.41</td> </tr> <tr> <td>SPDS 375</td> <td>.375 (.250)</td> <td>0.64</td> </tr> <tr> <td>SPDS 500</td> <td>.500 (.500)</td> <td>2.80</td> </tr> <tr> <td>SPDS 755</td> <td>.750 (.500)</td> <td>3.15</td> </tr> <tr> <td>SPDS 750</td> <td>.750 (.750)</td> <td>3.90</td> </tr> <tr> <td>SPDS 1075</td> <td>1.000 (.750)</td> <td>3.90</td> </tr> <tr> <td>SPDS 751</td> <td>.750 (1.000)</td> <td>7.00</td> </tr> <tr> <td>SPDS 1000</td> <td>1.000 (1.000)</td> <td>9.00</td> </tr> </tbody> </table>	Inch Model		Cv	Description	Line Size (Body) Size	SPDS 250	.250 (.250)	0.41	SPDS 375	.375 (.250)	0.64	SPDS 500	.500 (.500)	2.80	SPDS 755	.750 (.500)	3.15	SPDS 750	.750 (.750)	3.90	SPDS 1075	1.000 (.750)	3.90	SPDS 751	.750 (1.000)	7.00	SPDS 1000	1.000 (1.000)	9.00
	Inch Model		Cv																												
Description	Line Size (Body) Size																														
SPDS 250	.250 (.250)	0.41																													
SPDS 375	.375 (.250)	0.64																													
SPDS 500	.500 (.500)	2.80																													
SPDS 755	.750 (.500)	3.15																													
SPDS 750	.750 (.750)	3.90																													
SPDS 1075	1.000 (.750)	3.90																													
SPDS 751	.750 (1.000)	7.00																													
SPDS 1000	1.000 (1.000)	9.00																													
	Across the Seat	<1 x 10 <sup>-9</sup> scc/s He (1 x 10 <sup>-10</sup> Pa-M <sup>3</sup> /s)																													
	Outboard Pressure Test	<1 x 10 <sup>-6</sup> scc/s He (1 x 10 <sup>-7</sup> Pa-M <sup>3</sup> /s)																													
Cleanliness and Packaging	Assembled and tested in Class 10 Cleanroom. Purged and Final Packaged in Class 10 Cleanroom. Double-bag packaging with Ultra-High Purity N <sup>2</sup> gas environment.																														
Standard Finish	Electropolished to 10 Ra µin Max (0.25 µm) on all wetted surfaces																														
Options	Optional surface finishes available. Testing: particle, moisture, O <sub>2</sub> , SEM, ESCA and AES on request. Purge connections and Purge valves are available as requested. Face seal, twin ferrule compression fittings available up to 1" lines.																														

® Vespel is a registered trademark of DuPont Company.

## Order Information

Sample: SPDS - 500 - 049 - 1/2" FSM M(S) - PC2

SPDS Manual Valve with a 1/2" Tube End Connection x 1/2" Male Swivel with a 1/4" Up and Downstream Purge Connection

Series	Size	Inlet Connection	Outlet Connection <sup>1</sup>	Purge Type	Handle Colour <sup>2</sup>	Actuator Designator <sup>3</sup>	Actuator Accessories <sup>3</sup>
SPDS – Manual Multi Turn Version	250 (1/4")	¼" TE = 035	¼" TE = 035	Blank - No Purge	Blank (White Handwheel Supplied)	NC - Normally Closed	PS (Proximity Sensor)
SPDSA – Pneumatic Air Operated Version	375 (3/8")	3/8" TE = 035	3/8" TE = 035	PC1 - 1/4" Downstream Purge Connection	Red (Red Handwheel Supplied)	NO - Normally Open	PSEx (Explosion Proof Proximity Sensor)
	500 (1/2")	½" TE = 049	½" TE = 049	PC2 - 1/4" Up and Downstream Purge Connection	Yellow (Yellow Handwheel Supplied)		
	755 (3/4")	¾" TE = 065	¾" TE = 065	PC3 - 1/4" Upstream Purge Connection	Green (Green Handwheel Supplied)		
	750 (3/4")	1" TE = 065	1" TE = 065	PV1 - 1/4" Downstream Purge Valve	Orange (Orange Handwheel Supplied)		
	751 (3/4")	¼" FSM M	¼" FSM M	PV2 - 1/4" Up and Downstream Purge Valve	Black (Black Handwheel Supplied)		
	1000 (1")	¼" FSM FM	¼" FSM FM	PV3 - 1/4" Upstream Purge Valve	Blue (Blue Handwheel Supplied)		
		1/4" C/LOK	1/4" C/LOK		Pink (Pink Handwheel Supplied)		
		3/8" FSM FM	3/8" FSM FM		Brown (Brown Handwheel Supplied)		
		3/8" C/LOK	3/8" C/LOK		Gold (Gold Handwheel Supplied)		
		½" FSM FM	½" FSM FM		Grey (Grey Handwheel Supplied)		
		½" FSM M(S)	½" FSM M(S)		Silver (Silver Handwheel Supplied)		
		1/2" C/LOK	1/2" C/LOK		Purple (Purple Handwheel Supplied)		
		¾" FSM FM	¾" FSM FM				
		¾" FSM M(S)	¾" FSM M(S)				
		3/4" C/LOK	3/4" C/LOK				
	1" FSM FM	1" FSM FM					
	1" FSM M(S)	1" FSM M(S)					

FSM = Face Seal Metal - VCR® type connections  
100% compatible with VCR® brand

<sup>1</sup> Only Specify the Outlet connection when different from the Inlet connection

<sup>2</sup> Manual Version only

<sup>3</sup> Actuated Version only

# CARTEN

FLOW SOLUTIONS - **WE GO BEYOND**

Carten Controls Ltd.,  
Unit 613, Northern Extension  
Waterford Industrial Park,  
Waterford Ireland

Tel: +353 (0)51 355436  
Email: [sales@cartencontrols.com](mailto:sales@cartencontrols.com)  
Website: <http://www.cartencontrols.com>

Fujikin (Deutschland) GmbH  
Immermannstraße 33 -  
D-40210 Düsseldorf, Germany.

Tel: +49 (0) 211-350458  
Email: [info@fujikin.de](mailto:info@fujikin.de)  
Website: <http://www.fujikin.de>

Carten Controls and Fujikin Deutschland are members of the Fujikin Carp Group (FCG) with Headquarters in Osaka Japan.