

2028 SERIES

Ultra-High Purity Vacuum Generators



PRODUCT APPLICATIONS

This stainless steel Vacuum Generator Series is nitrogen operated and is available with single or dual vacuum ports. Applications for this generator include:

- Primary vacuum generation in gas cabinets
- Chamber evacuation for semiconductor manufacture
- Dilution of vented gases

PRODUCT FEATURES

- ▶ High Performance/Compact Design
- ▶ Lowest Nitrogen Consumption to Obtain Max. Vacuum
- ▶ Requires Only 1.6 scfm N₂ at 60 psig to Achieve 27 in. Hg Vac.
- ▶ Compatible with Standard Face Seal Fittings
- ▶ 100% Tested for Vacuum Performance and External Leakage
- ▶ Ultrasonically Cleaned to Semiconductor Ultra-High Purity Standards
- ▶ Purged and Final Packaged in Class 1 Cleanroom. Double-bag Packaging with N₂ Gas Supplied from a Liquid Source.
- ▶ High Velocity Nozzles

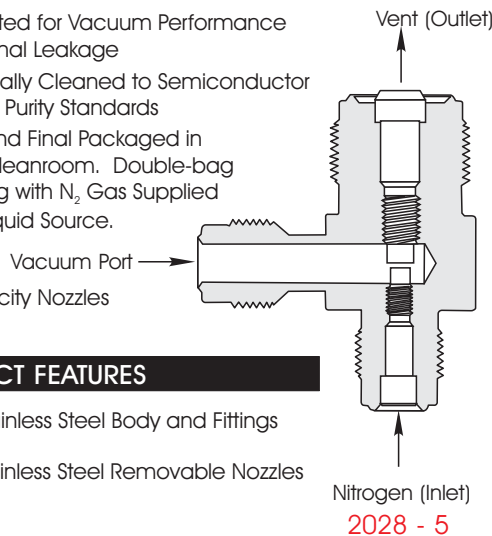

PRODUCT FEATURES

- 316 L Stainless Steel Body and Fittings
- 316 L Stainless Steel Removable Nozzles

2028 SERIES - Product Dimensions

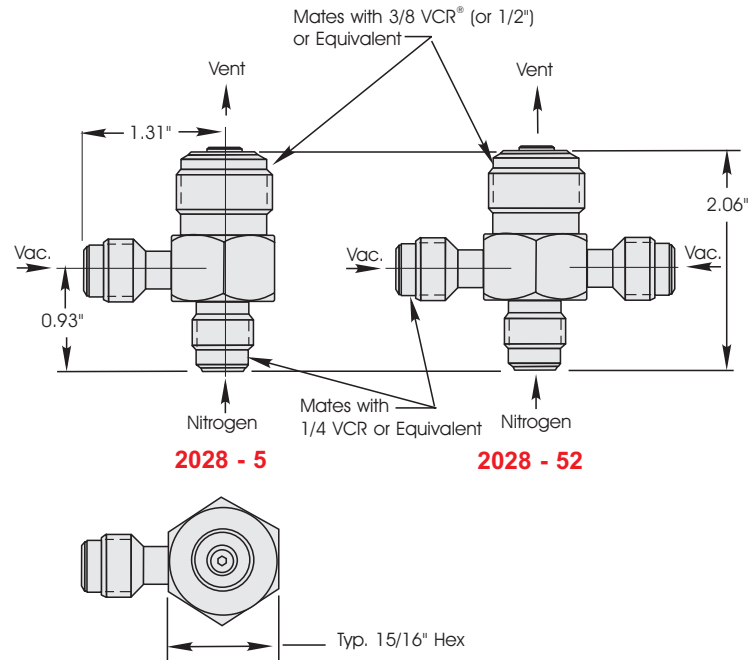

2028 SERIES - Technical Data

CONSTRUCTION MATERIAL	Wetted Areas	316 L Stainless Steel
	Non-Wetted Areas	316 L Stainless Steel
VACUUM	2028 Series	27" of Hg with inlet nitrogen pressure at 60-80 psig
ENTRAINMENT RATIO	2028 Series	Approx. 7:1 at 1 ATM
NITROGEN FLOW	2028 Series	Maximum 2.7 scfm of N ₂ @ 80 psig
CLEANLINESS/ PACKAGING	Assembled and tested in CLASS 10 cleanroom. Purged and final packaged in CLASS 1 cleanroom. Double-bag packaging (2 mil nylon inner bag, 6 mil polyethylene outer bag) with N ₂ gas environment supplied from a liquid source	
STANDARD FINISH	Electropolished to 16 Ra (0.41 Ra m) on all wetted surfaces	
OPTIONS	Weld on tube extension	

HELIUM LEAK TEST	Inboard	1 x 10 ⁻¹⁰ SCC/S He max.	Rated
		1 x 10 ⁻⁹ SCC/S He max.	Std. Production
Helium leak test performed with 100% He			

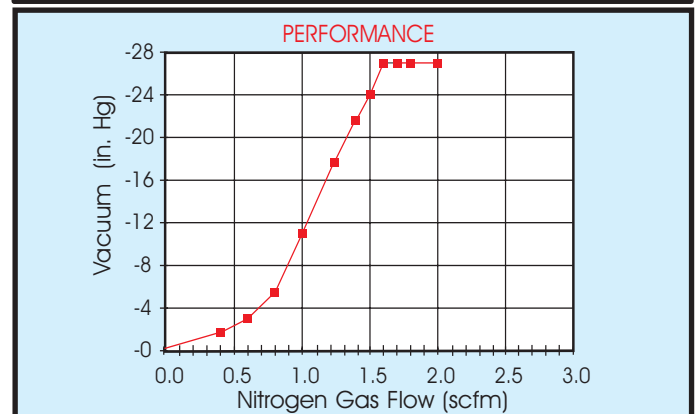

Specifications are subject to change without notice.
VCR is a registered trademark of the Cajon Company

REV. 99-1

NOTE 1: Dimensional drawings shown are for reference only. Please contact the manufacturer for customer drawings showing updated dimensions.

CARTEN CONTROLS INC.